

VerroLoc Circular Jointing System

Circular Flange Ring Details & Specifications

- Suitable for straight seamed or spirally wound ducts.
- Reduces fabrication and installation time compared to RSA Flanges.
- Easy removal of duct sections for cleaning or maintenance purposes.
- Accuracy of production ensures minimum efforts to fit flange ring to duct.
- Easier installation in confined spaces when compared to RSA Flanges.
- Independently tested by BSRIA, proven to work within requirements of UK HVCA Specification DW144.
- A sealant pocket is rolled into the profile allowing effective sealing of ring to duct. A permanent non-setting, non-toxic sealant can be injected into the profile if requested.
- Quick closure and release latch with safety wedge available up to 900mm diameter for rapid removal of duct sections.
- Manufactured from Galvanised Mild Steel for corrosion resistance, avoids need for secondary painting. Also available in 304L & 316L Stainless Steel.



Design Specification

All connections between straight seamed or spirally wound circular ductwork sections should be made using the appropriately sized VerroLoc Circular Jointing System. As standard Flange Rings are supplied without integral sealant, unless the rings are made to order and integral sealant is requested. It is the customer's responsibility to effectively seal the ring to the duct. A suitable permanently non-setting sealant can be provided if requested. The system will be installed using the appropriate VerroLoc closure ring in accordance with the manufacturer's instructions. The inclusion of a metal biscuit joint (standard on 20 & 30mm rings) between the two ends aids in realigning the ring when securing it onto the duct.

The system shall satisfy the Air Leakage requirements of HVCA Specifications DW143 and DW144 and shall be independently tested by BSRIA.

VerroLoc System

Designed specifically to provide an economical method of jointing for circular ducts. The VerroLoc Circular Jointing

VerroLoc System cont.

System comprises two flange profiles produced to suit the required duct diameter, each flange profile is complete with integral sealant to provide an airtight connection when correctly fitted to the end of the duct section, please see Fig. 1 below. On site the duct sections are assembled using the provided closure ring.

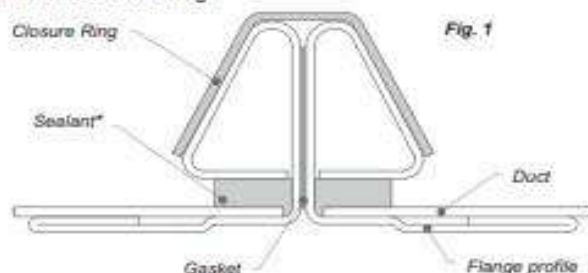

* Sealant (manually sealed during fitting or injected into the profile at the time of manufacture).

Independent Air Leakage Test Results

In the absence of established Industry testing procedures the VerroLoc Circular Jointing System was independently tested in accordance with the HVCA air leakage test procedures for Ductwork Jointing Systems DW/TM1**.

Circular Flange Ring profiles & pressure classes

Profile	Size Range (mm)	Pressure Class					
		A		B		C	
	Closure Ring	Latch	Stud	Latch	Stud	Latch	Stud
VerroLoc 15	200-355	✓	✓	✓	✓	X	✓
VerroLoc 20	400-900	✓	✓	✓	✓	X	✓
VerroLoc 30	1000-2000*	✓	✓	✓	✓	X	✓

* Diameter over 1600 please refer to the sales office for further details.
** In-house testing witnessed by BSRIA using BSRIA approved test rig.

Product Details & Specifications

Flange Ring

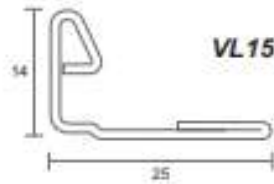

VL15

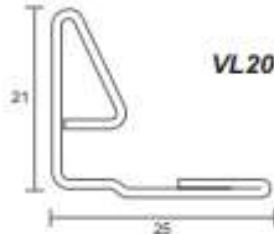

VL20



VL30

Closure Ring

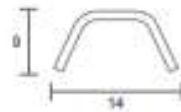

All measurements are in millimetres

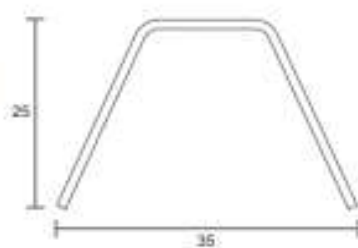
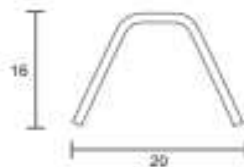

Material Specification

	gauge (mm)
VL15 Flange Ring	0.8
VL15 Closure Ring	0.8
VL20 Flange Ring	1.0
VL20 Closure Ring	1.0
VL30 Flange Ring	1.2
VL30 Closure Ring	1.2

BS EN 10142:2000, with coating specification BS EN 10346:2015 DX51D +Z275 MAC. Integral sealant - DVS01 non-toxic permanently non-setting flange sealant can be injected at time of manufacture.

Stainless Steel available to special order.

Packing Details

	Qty
VL15 Complete Joints	10
VL20 Complete Joints	5
VL30 Complete Joints	1

As standard all VerroLoc Joints are supplied complete, comprising of 2 off flange profiles & 1 off Closure Ring. Single Flange Profiles or Closure rings can be supplied to order.

Fabrication & Installation

Complete fabrication & installation instructions are available upon request and should be strictly adhered to, to ensure optimum performance of the VerroLoc System.

Gasket

A cross linked Medium Density P.V.C. closed cell foam combined with a high grab sensitive adhesive to give good all round sealing properties. Temperature range -40°C to +70°C. We recommend the use of the appropriate gasket to ensure performance in accordance with our DW/TM1 test results, where application allows. Supplied in green for easy identification.

Closure Ring End Fitting

Standard closure rings are supplied with a stud fitting, should a latch be required this should be specified at time of ordering.

Fig. 1 Galvanised steel stud fixing, with welded collar and safety locking nut to prevent loosening under load conditions.

Fig. 2 Galvanised steel closure arm with stainless steel spring for positive action, complete with safety wedge to prevent accidental opening.

Size Ranges and Weights

VerroLoc 15	Diameter	200	224	250	280	300	315	355		
	Weight (kg)									
	Flange Ring	0.21	0.24	0.27	0.30	0.32	0.34	0.38		
	Closure Ring	0.07	0.08	0.09	0.10	0.11	0.11	0.13		
	Joint	0.49	0.56	0.63	0.70	0.75	0.79	0.89		
VerroLoc 20	Diameter	400	450	500	560	600	630	710	800	900
	Weight (kg)									
	Flange Ring	0.43	0.48	0.90	1.00	1.10	1.16	1.20	1.40	1.60
	Closure Ring	0.15	0.16	0.50	0.50	0.60	0.63	0.70	0.80	0.90
	Joint	1.01	1.12	2.30	2.50	2.80	2.95	3.10	3.60	4.10
VerroLoc 30	Diameter	1000	1120	1250	1400	1422	1500	1600	2000	
	Weight (kg)									
	Flange Ring	3.60	4.10	4.60	5.10	5.20	5.50	5.80	7.30	
	Closure Ring	2.00	2.20	2.50	2.80	2.80	3.00	3.10	3.90	
	Joint	9.20	10.40	11.70	13.00	13.20	14.00	14.70	18.50	

* Nominal weights for guidance purposes only; all measurements in millimetres.

Other sizes are available to order

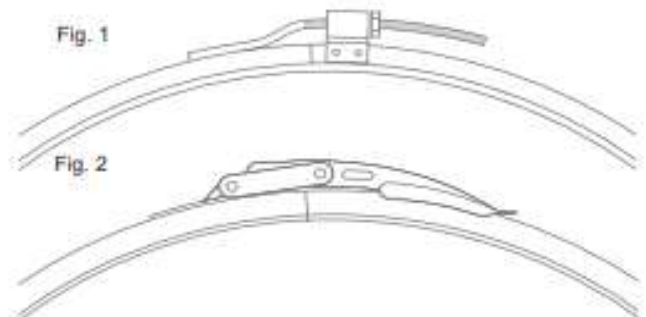



VerroLoc Circular Jointing System



Assembly Instructions

Each joint comprises of 2 flange rings and 1 closure ring and are supplied together for easier transportation. To start the assembly, slacken the nut or release the closure ring of the closure ring, dependent on closure ring selected, to separate the closure rings from the two flange rings. (Fig.1)

The VerroLoc circular joint is supplied with no sealant as standard, but can be applied post manufacture by the installer to the joint prior to fitting to the duct if required. Create a 5mm thick continuous bead around ring as shown below (Fig.2) with only Doby recommended sealant.

Please note: When rings are ordered with the optional integral sealant at time of rolling it is not necessary to be manually sealed.

On all ducts where the spirally wound seam is too high to be enclosed by the flange (A). The seam must be ground down to accommodate the flange allowing it to sit properly (B) (Fig.3). Please note, care must be taken when grinding back to ensure the seam integrity is maintained.

Push one flange ring onto one end of the duct, starting with one end of the break point in the flange ring and working around the duct until the flange ring is completely seated on the end of the duct. To ensure a good seal, when selecting a starting point, where possible position the break point of the flange ring a minimum of 100mm from the cut seam of the spirally wound ductwork. The flange rings are manufactured to high tolerances and are designed to be fitted without the need for cutting. On occasions however it may be necessary to cut back the flange ring to give the optimum fit. (Fig.4)

Once the flange ring is in the correct position the ring must be secured to the duct, as shown opposite, the Fastening fixing point dimension "A" is variable according to the size of the Flange as shown below:

VL15 15 mm, VL20 12 mm Min. 15 mm Max, VL30 20 mm Min. 25 mm Max.

At one point on the cut end of spirally wound duct the seam of the duct will pass into the pocket of the flange, care must be taken when using a fastener at this point to ensure a positive fixing, although the above dimensions may not be possible. (Fig.5)

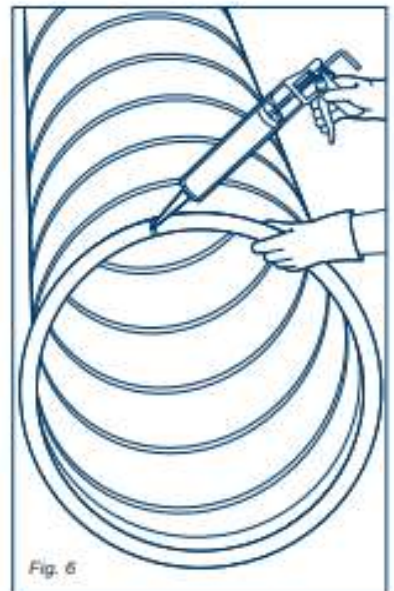
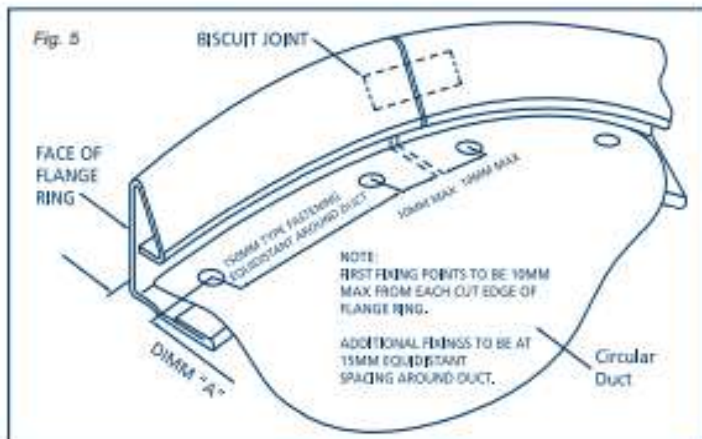
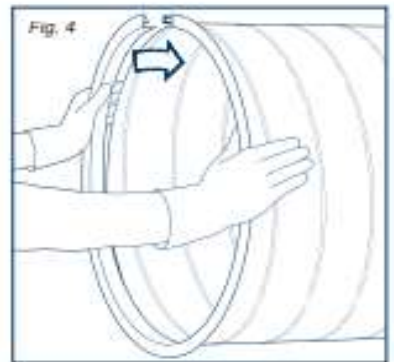
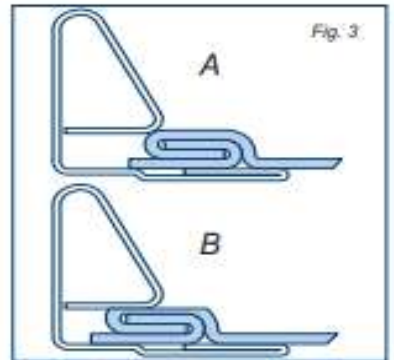
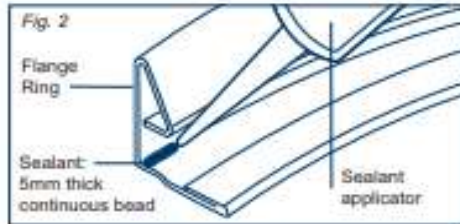

To complete the fitting of the flange ring a bead of silicon sealant should be applied down the seam where the break in the flange ring occurs. This can be undertaken at the time of fitting the flange ring or to avoid being damaged in transit could be applied just prior to installation. The process is then repeated on the opposite end of the duct with the second flange ring. (Fig.5)





VerroLoc Circular Jointing System

Installation Instructions

If not applied at the time of assembly, apply a bead of silicon sealant along the full length of the internal break of the flange profile. This process to be undertaken on each pair of mating flanges. (Fig.6)

Thread closure fixing

When using Closure ring with thread Fixing - Place closure ring over end of duct. Line up mating ducts, ensure that the break in each flange ring is not in line. (Fig. 7)

Clamp the two flange rings together using the appropriate vice clamps, ensuring that the vice clamps also go over the closure ring; more than one pair of clamps may be required dependant on the duct size. Fit the closure ring around the two mating flange rings, ensuring both ends overlap (as diagram below) before finally tightening the locking nut to pull both faces of flange rings together, remove vice clamps.

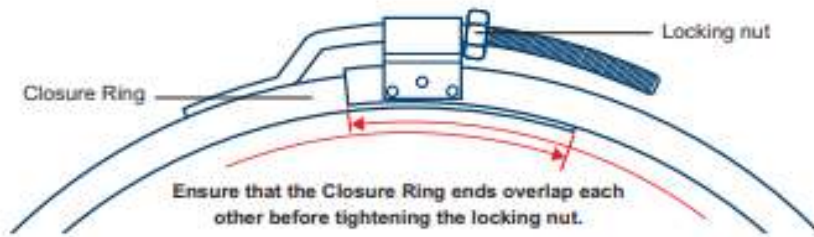

Using a rubber mallet, tap around the outer edge of the closure ring to ensure flange rings are correctly aligned; tighten bolt as required. Note: Extreme care must be taken when installing any ductwork sections, working at heights can be dangerous. (Fig. 8)

Clasp closure fixing

When using the Clasp Closure ring - Place closure ring over end of duct. Line up mating ducts, ensuring that the break in each flange ring is not in line. (Fig. 9)

Clamp the two flange rings together using the appropriate vice clamps ensuring that the vice clamps also go over the closure ring, more than one pair of clamps may be required dependant on the duct size. Fit the closure ring around the two mating flange rings, pull over the closing arm to pull the two sections together, remove the vice clamps.

Using a rubber mallet tap around the outer edge of the closure ring to ensure flange rings are correctly aligned, engage safety arm, insert safety wedge to prevent accidental opening.

Note: Extreme care must be taken when installing any ductwork sections, working at heights can be dangerous. (Fig.10)

