

Short segmented bends

B45



Description

Segmented bends are designed for SPIRAL ducts and plain ducts. They are made of 4 segments; the bends in diameters of DN 1120 mm and greater are made of 5 segments. The segments are fastened by hemming and seaming. Bend sizes of 1.5D or 2D are available by adding segments to reduce the pressure loss and the flow resistance along the ventilation system. The piece is connected with a duct by inserting one into the other. The pieces can be made of 1.4301 stainless steel sheet for ventilation systems in swimming pools.

Product code example

Product code: **BSK - aaa - 45**

type _____
 $\varnothing d_1$ _____
 angle _____

Dimensions

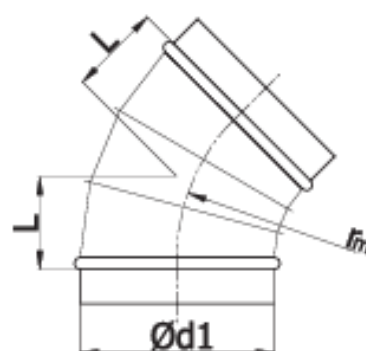

$$r_m \approx 0.6 \times d_1$$

$\varnothing d_{1 \text{ nom}}$ (mm)	L (mm)	Weight (kg)
200	60	0.50
224	60	0.55
250	65	0.70
280	70	0.90
300	80	1.00
315	85	1.00
355	95	1.20
400	145	1.50
450	158	2.20
500	170	2.60
560	190	3.20
600	200	4.20
630	207	4.60
710	245	5.70
800	265	7.00
900	290	11.10
1000	330	13.40
1120	395	16.80
1250	430	20.40
1400	455	28.00
1500	480	31.70
1600	500	35.80